



# Michigan Radio Control Association

## **MRCRA Newsletter – Meeting of February 1, 2010.**

### **Club Officers and Information:**

**President - Pete Smith; Warner Johnson - Vice President; Lee Evans - Secretary; Barbara Noye - Treasurer, 76 W. Willis Road, Saline, MI 48176, Phone: 734-429-3249;**

**Walt Trancygier – Newsletter – [trancywj@comcast.net](mailto:trancywj@comcast.net), Phone: 734-552-4581 - Club website: [www.mrcaclub.org](http://www.mrcaclub.org)**

**Note: The next REGULAR meeting will be on Monday March 1, 2010 beginning at 7:00 P.M. at **the normal Ypsilanti Town Hall meeting location.****

### **Secretary and Presidents Report**

MRCRA February 1, 2010

In Attendance- Tom Czinski, Jim Childers, Phil Kwiecinski, Walt Trancygier, Phil Smith, Lyle Mead, John Chie, Warner Johnson, Barb Noye, Ralph Silvey, Peter Smith

Meeting was called to order at 7:04 PM

**Old Business:** Old business consisted of a brief review of last meetings discussion about the fun-fly's, maintaining the two traditional ones we have had in June and September and adding one in late August for the sail-planes.

There are only a few unpaid members that we know of. Let's get caught up on this and be done with it for the year.

**New Business:** Items brought to the table.

Jim Childers, who has almost single-handedly maintained the field for us for the last few years, is stepping down in this capacity. He has done a really fantastic job and we all have benefited from his hard work. This leaves us with some big decisions to make.

Who will take over this position? Should we hire a service? Should we act upon a voluntary basis? What about the condition of our *tractor* and equipment?

It is important that we get a handle on this now as it will be spring soon and we will be left in a mess, if we don't have a plan set up to accommodate the field maintenance.

Here is some important information to consider.

The *tractor* is in need of some serious and expensive repair. It is very tricky to run right now and it is likely to finally stop dead if abused or misused. It might be possible to nurse this through another year but more than likely it will not make it. The cost of the repairs is beyond the worth of this particular tractor. (\$3500-\$4000) A vote was taken and passed to put a cap of \$4000 on the purchase of a newer tractor with the hope being that we can find one for a good deal less. The motion was passed but not unanimously.

In the past the big mower has been hitched up to trucks and towed around the field. This is I believe how it is done at Milan's Field. The Power Mower or Bush Hog requires the Power Take Off of the tractor.

Possible Solutions.

1. Buy a new Tractor. (Pro- A more sound machine would be a lot easier than the current one to operate. It would remain on site and be available throughout the flying season. Con- It will be a substantial cost to our organization. It will require steady maintenance, experienced and knowledgeable drivers would work best if one person were in charge of operations.)
2. Hire a service. (Pro- we wouldn't have any member in charge of the actual labor of mowing. Con - Depending on the number of times mowed per season this could become expensive as well.) A variation on this was to hire from within and pay a member to take on this as a job, for possibly less than what a service would cost.
3. Run a voluntary campaign to keep the field maintained. (Pro- cost would be low and it would promote a vested interest in the field. Con- Volunteerism, while in theory is great, is fraught with pitfalls and would need some overseeing body to make sure that things were being done when they need to. It would bring us back to the issues of the tractor and who can operate it and safety.)

These are some of the issues we have to solve now before we find ourselves trying to fly from an overgrown field of weeds.

This is something that affects the whole club and is vital to the enjoyment of the club as a whole, so if you have some ideas to weigh in with then by all means do so. It would be great to bring your ideas to the next meeting but if you think of something I would welcome an e-mail or phone call.

Peter Smith

[peter@petersmithphoto.com](mailto:peter@petersmithphoto.com)

(734) 657-5978

## President's Notes

My personal take on this dilemma is that regardless of whether we buy a tractor, run with the one we have for another year, or hire a service, someone needs to be in charge of Field Maintenance. In other words...and none of this is addressed in the current version of the by-laws, I just read them and there is no such officer mentioned, we need a Field Marshal.

I propose that we add a new officer to the line-up. That this officer's duties are to oversee the maintenance of the field. This does not mean that the officer will have to physically take on the chore of mowing the field himself. It merely establishes a central point of authority in regards to the maintenance of the field.

I think that safety is of huge concern when operating any equipment associated with field maintenance and that no one should take on any of these duties who has not been trained and checked out by and approved by the Field Marshal. I feel that essentially a small handful of people to maintain the field, a Primary Cutter, The one who would mow most frequently and a Secondary Cutter as a back-up, subject to yearly review and or replacement and operating under the auspices of the Field Marshal, would be a good way to ensure that the job

gets done, that it gets done safely, and that the equipment is being properly maintained. The question is do we have the appropriate membership to accomplish this? Do we have Someone within our ranks who will take on the position of Field Marshal? Primary Cutter? Secondary Cutter? Equipment Mechanic? This is a lot of responsibility for one person to assume and I think that by arranging an appointed committee the burden would be less.

Am I making too big of a deal about this? Is this too much work to expect from our small group? Are all these suggestions of new officer and Primary and Secondary cutter unnecessary. Weigh-in and let your thoughts be heard.

See you at the next meeting.

Peter Smith

Tom Czinski brought along his Blade Helicopter which was flown around the room much to everyone's amusement before the meeting started



Peter Smith is working on a P-47 Foam 48 EP

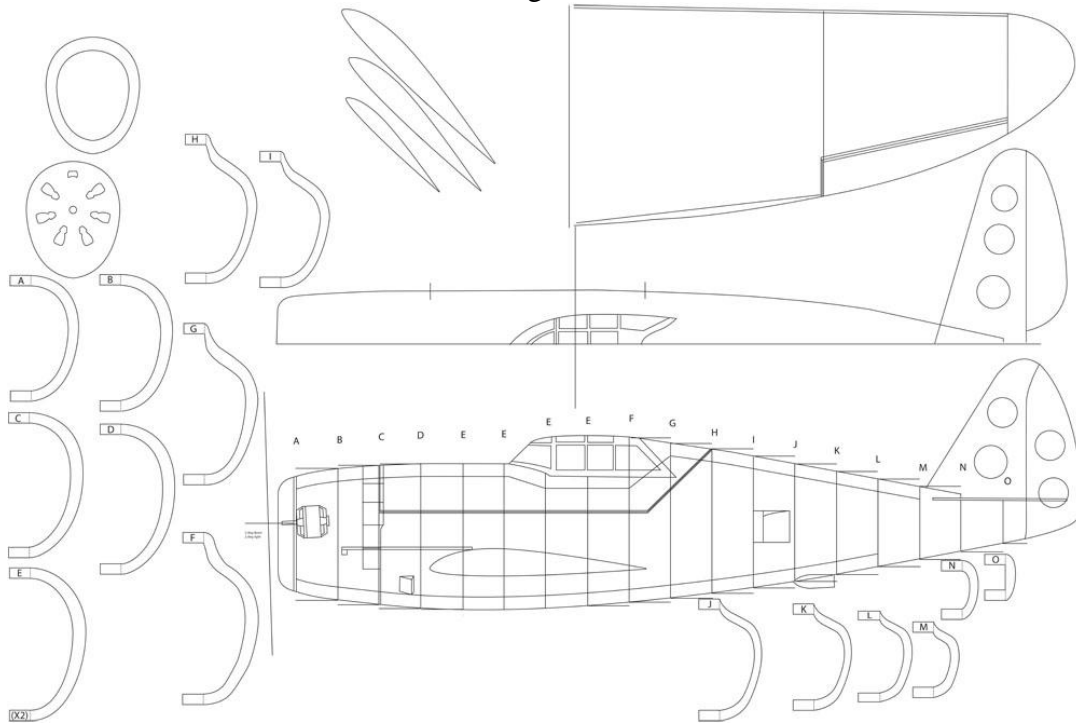

I started looking for a P-47 last year and I never found what I really wanted. The kits were either too big or the foamies were too small or they were the bubble top and I wanted a razorback or I didn't like the paint scheme. I ran across this great build thread on RC Groups.com for a 48 inch Foam Electric Scratch Build. You can check this out online at <http://www.rcgroups.com/forums/showthread.php?t=985102> I am basically following the same plans and sequence that this fellow does and I am having a blast figuring out how to get this all together and flying. I will be keeping a personal build thread on my Blog RC Modeling as I plan to model this plane after one of the ones my dad flew with the 56<sup>th</sup>.

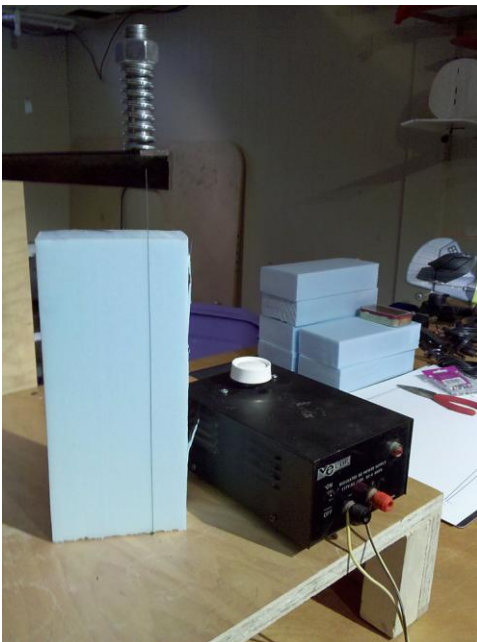

Using a Hot-Wire "Band Saw" I made with the help of several friends I am cutting out the foam sections of the fuselage that will be glued to a balsa or ply Keel. The foam is two inch thick Blue Board I bought at Lowes..

## **Editors Notes**

Lee Evans was not at this meeting so Peter assumed the duties of club president and secretary. The pictures from the January 2010 meeting are compliments of Peter. Peter has done an excellent job of taking notes from the meeting and explaining some of the issues the club faces with regards to field maintenance in the future. As he has stated we have to make some important decisions soon. Jim Childers has done an exemplary job of taking care of the field for a number of years. Thank you Jim.

Later.

Walt T.